

Color	Type	Technology	Case
White	W-T110-350	InGaN/Al <sub>2</sub> O <sub>3</sub>	TO220, short pins

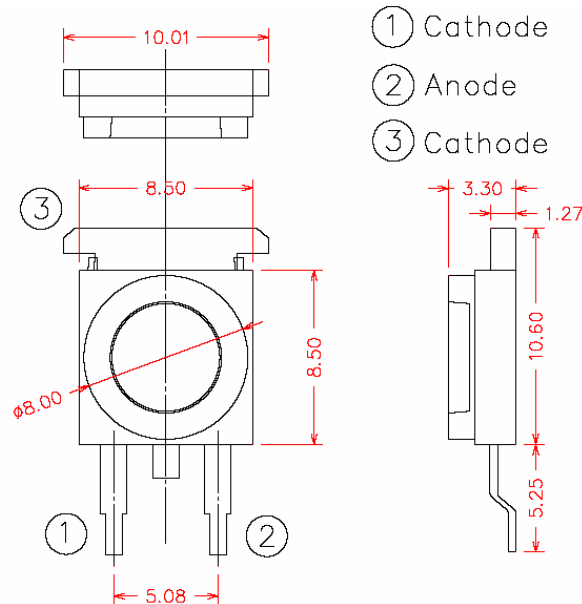

### Maximum Ratings at $T_a = 25^\circ\text{C}$

Parameter	Test conditions	Symbol	Value	Unit
Forward current		$I_F$	350	mA
Peak forward current	Duty 1/100, $f \leq 1$ kHz	$I_{FP}$	400	mA
Power dissipation		$P_D$	1.4	W
Reverse voltage	$I_R = 10 \mu\text{A}$	$V_R$	5	V
Reverse current	$U_R = 5$ V	$I_R$	50	$\mu\text{A}$
Electrostatic discharge	Human body model	ESD	8000	V
Operating temperature		$T_{opr}$	-30 to +85	$^\circ\text{C}$
Storage temperature		$T_{stg}$	-40 to +120	$^\circ\text{C}$
Soldering temperature	5 sec max, 2 mm from body	$T_{sol}$	260	$^\circ\text{C}$

### Electrical and Optical Characteristics at $T_a = 25^\circ\text{C}$

Parameter	Test conditions	Symbol	Min.	Typ.	Max.	Unit
Forward voltage	$I_F = 350$ mA	$V_F$	3.0	3.5	4.0	V
Luminous flux	$I_F = 350$ mA	$\Phi_V$	18	30		lm
Correlated color temperature	$I_F = 350$ mA	CCT	3000	-	9000	K
Viewing angle	$I_F = 350$ mA	$\varphi$	-	110	-	deg.
Thermal resistance junction to board	$I_F = 350$ mA	$R\theta_{J-B}$	-	22		K/W