

# IR-880-3160M3A

# Infrared Emitting Diode

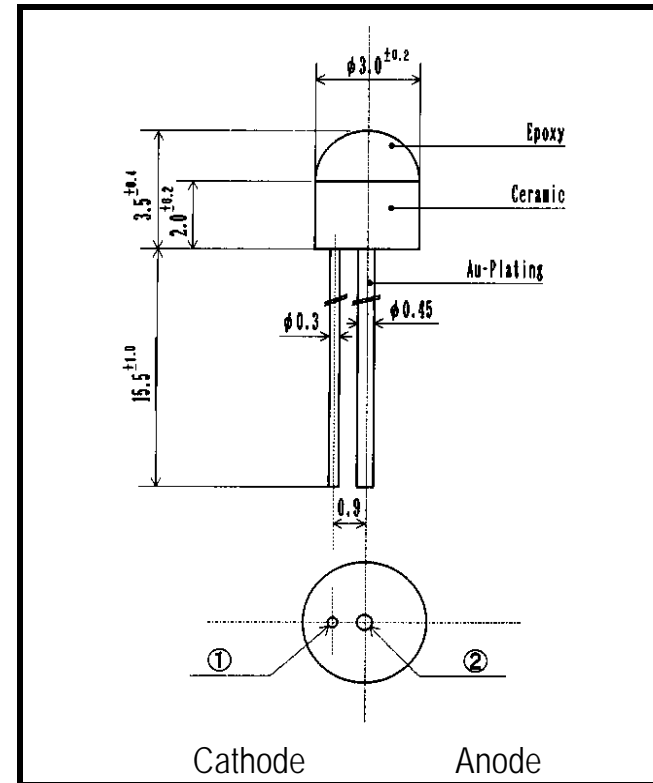

- FEATURES**
- High-output Power
  - Compact
  - High Reliability
- APPLICATIONS**
- Optical Switches
  - Optical Sensors

## 1. ABSOLUTE MAXIMUM RATINGS (Ta=25 °C)

ITEM	SYMBOL	RATINGS	UNIT
Forward Current (DC)	IF	50	mA
Forward Current (Pulse)*1	IFP	0.5	A
Reverse Voltage	VR	5	V
Power Dissipation	PD	100	mW
Operating Temp.	Topr	-20 TO 85	
Storage Temp.	Tstg	-30 TO 100	
Junction Temp.	Tj	100	
Lead Soldering Temp.*2	Tls	260	

\*1:Tw=10uS,T=10mS

\*2:Time 5 Sec max,Position:Up to 3mm from the body

## 2. ELECTRICAL & OPTICAL CHARACTERISTICS (Ta=25 °C)

ITEM	SYMBOL	CONDITIONS	MIN	TYP	MAX	UNIT
Power Output	PO	IF=20mA		4.5		mW
Forward Voltage	VF	IF=20mA		1.3	1.6	V
Reverse Current	IR	VR=5V			10	$\mu$ A
Peak Wavelength	$\lambda$	IF=20mA		880		nm
Spectral Line Half Width		IF=20mA		60		nm
Half Intensity Beam Angle		IF=20mA		$\pm 80$		deg.
Rise Time	Tr	IFP=50mA		1.5		$\mu$ S
Fall Time	Tf	IFP=50mA		0.8		$\mu$ S
Junction Capacitance	Cj	1MHz, V=0V		15		pF
Temp. Coefficient of PO	P/T	IF=10mA		-0.5		%/°C
Temp. Coefficient of VF	V/T	IF=10mA		-1.5		mV/°C

SPECTRAL OUTPUT

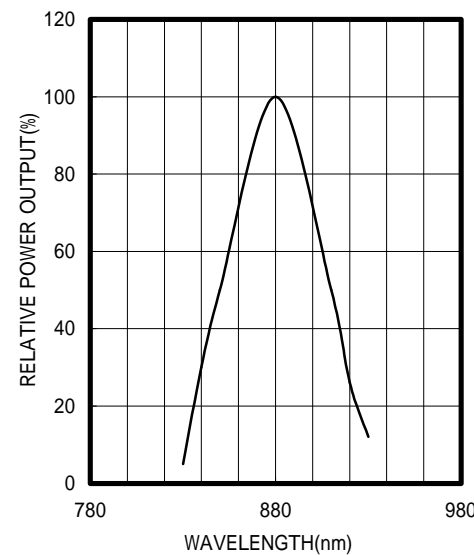

FORWARD I-V CHARACTERISTICS

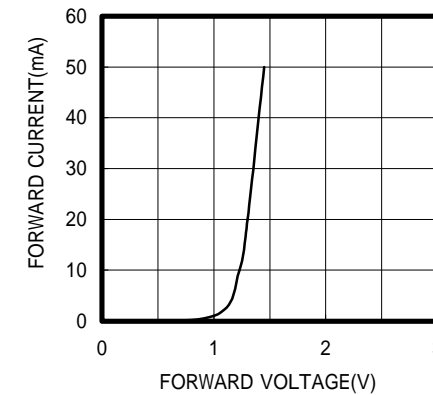

RELATIVE POWER vs FORWARD CURRENT

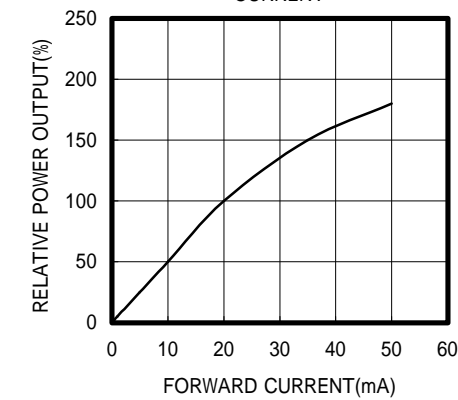

RADIATION PATTERN

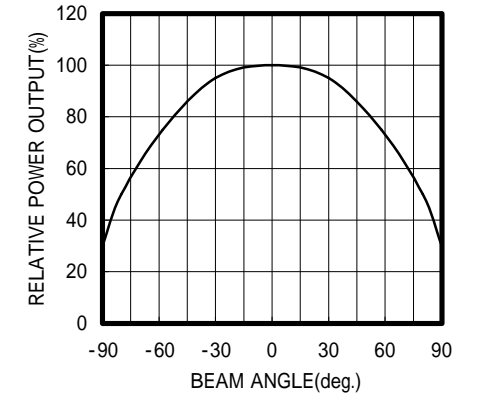

THERMAL DERATING CURVE

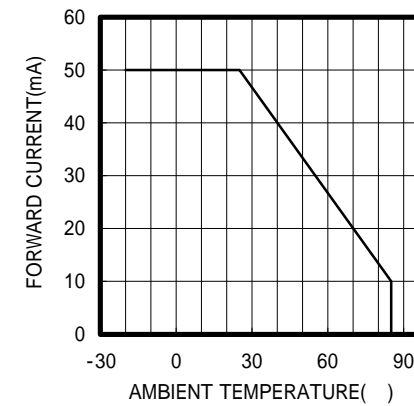

POWER OUTPUT vs TEMPERATURE IF=10mA

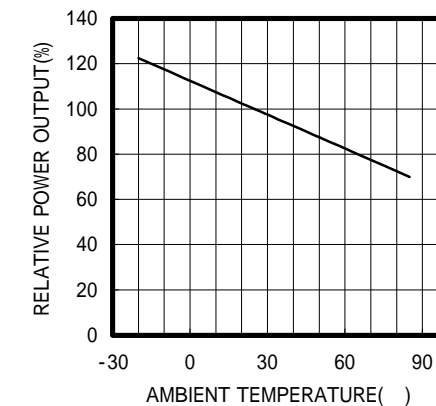

FORWARD VOLTAGE vs TEMPERATURE IF=10mA

