

YG-574-TO-40TM

Visible Light Emitting Diode

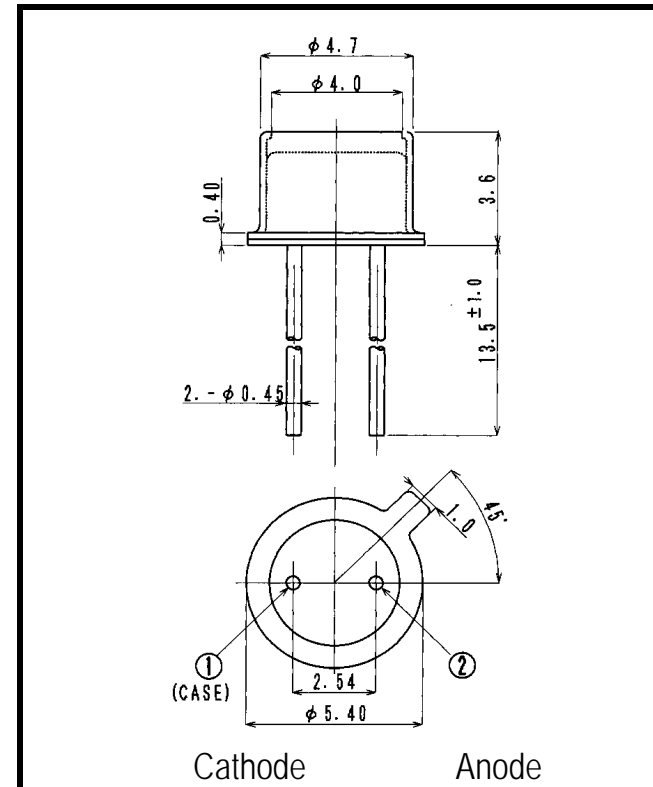
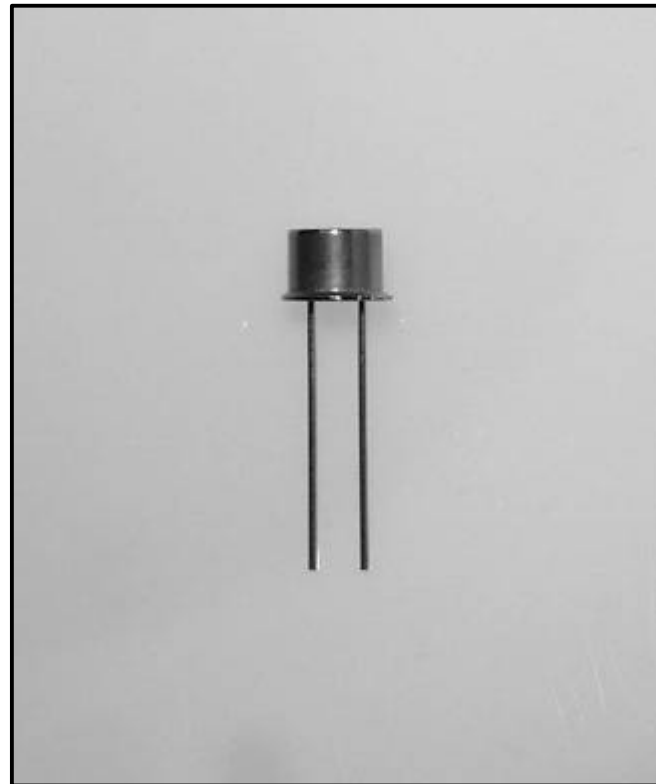

- FEATURES**
- High-output Power
 - High Reliability
- APPLICATIONS**
- Color Sensor (Money-bill)
 - Paper Sensor (Money-bill)
 - Bar-code Reader
 - Fiber Applications

1. ABSOLUTE MAXIMUM RATINGS (Ta=25 °C)

| ITEM | SYMBOL | RATINGS | UNIT |
|---------------------------|--------|------------|------|
| Forward Current (DC) | IF | 50 | mA |
| Forward Current (Pulse)*1 | IFP | 0.5 | A |
| Reverse Voltage | VR | 5 | V |
| Power Dissipation | PD | 140 | mW |
| Operating Temp. | Topr | -20 TO 85 | |
| Storage Temp. | Tstg | -30 TO 100 | |
| Junction Temp. | Tj | 100 | |
| Lead Soldering Temp.*2 | Tls | 260 | |

*1:Tw=10uS,T=10mS

*2:Time 5 Sec max,Position:Up to 3mm from the body

2. ELECTRICAL & OPTICAL CHARACTERISTICS (Ta=25 °C)

| ITEM | SYMBOL | CONDITIONS | MIN | TYP | MAX | UNIT |
|---------------------------|--------|------------|------|------|-----|-------|
| Power Output | PO | IF=20mA | 0.15 | 0.3 | | mW |
| Forward Voltage | VF | IF=20mA | | 2.3 | 2.7 | V |
| Reverse Current | IR | VR=5V | | | 100 | μA |
| Peak Wavelength | λ | IF=20mA | | 574 | | nm |
| Spectral Line Half Width | | IF=20mA | | 11 | | nm |
| Half Intensity Beam Angle | | IF=20mA | | ±20 | | deg. |
| Rise Time | Tr | IFP=20mA | | - | | nS |
| Fall Time | Tf | IFP=20mA | | - | | nS |
| Junction Capacitance | Cj | 1MHz, V=0V | | 20 | | pF |
| Temp. Coefficient of PO | P/T | IF=10mA | | -0.6 | | %/°C |
| Temp. Coefficient of VF | V/T | IF=10mA | | -2.4 | | mV/°C |

Cathode Anode
Dimensions (Unit:mm)

SPECTRAL OUTPUT

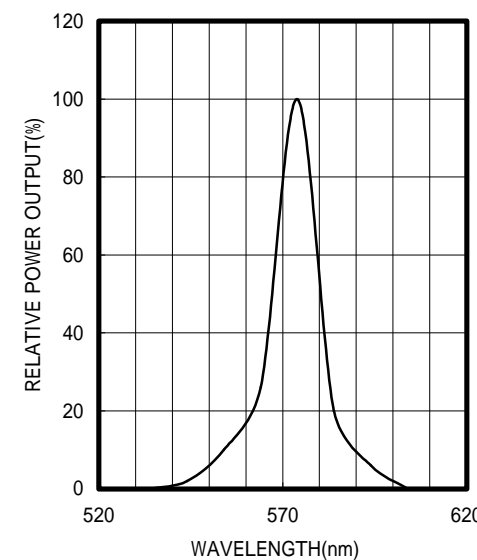

FORWARD I-V CHARACTERISTICS

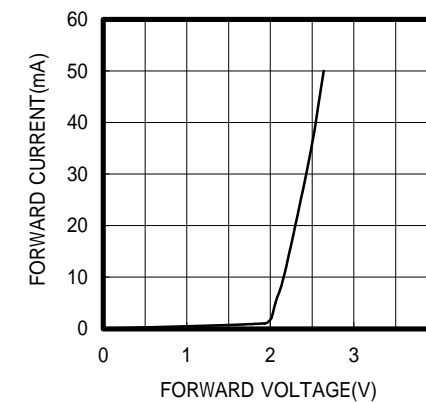

RELATIVE POWER vs FORWARD CURRENT

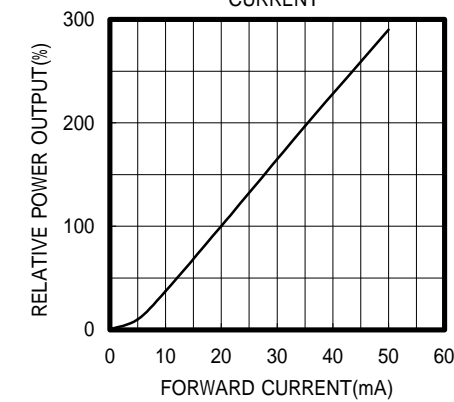

RADIATION PATTERN

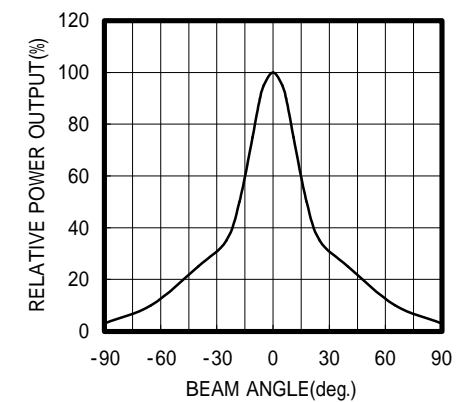

THERMAL DERATING CURVE

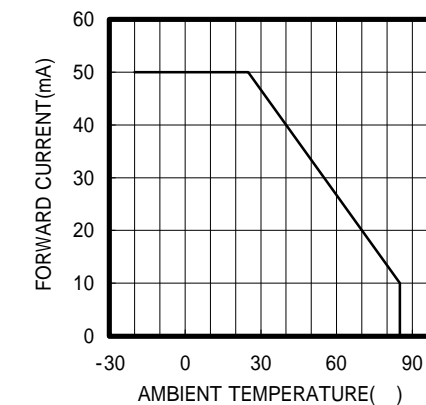

POWER OUTPUT vs TEMPERATURE IF=10mA

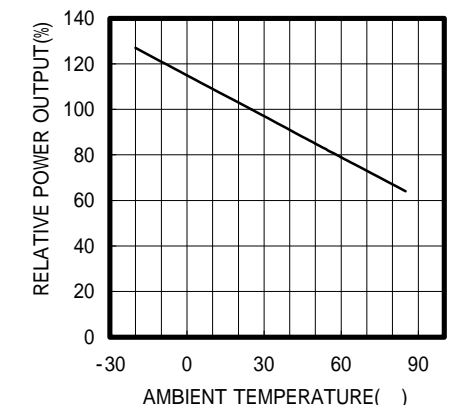

FORWARD VOLTAGE vs TEMPERATURE IF=10mA

